

BAT54 /A/C/S

SWITCHING DIODES

FEATURES

•Extremely Fast Switching Speed

•Marking:

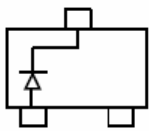
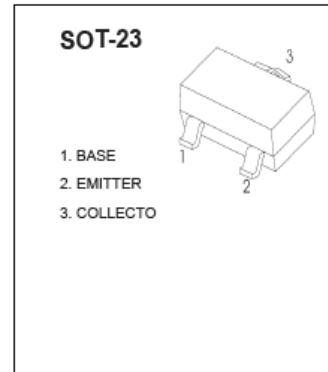

BAT54 MARKING: KL1

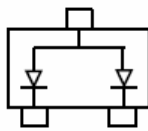

BAT54A MARKING: KL2

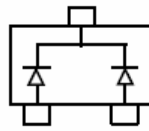

BAT54C MARKING: KL3

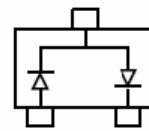

BAT54S MARKING: KL4

Maximum Ratings @ $T_A=25^{\circ}\text{C}$

Parameter	Symbol	Limits	Unit
Peak Repetitive Peak reverse voltage	V_{RRM}	30	V
Working Peak Reverse Voltage	V_{RWM}		
	V_R		
Forward Continuous Current	I_{FM}	200	mA
Power Dissipation	P_D	200	mW
Storage temperature	T_{STG}	-55-150	$^{\circ}\text{C}$

Electrical Characteristics @ $T_A=25^{\circ}\text{C}$

Parameter	Symbol	Min.	Typ.	Max.	Unit	Conditions
Reverse Breakdown Voltage	$V_{(BR)R}$	30			V	$I_R=100\mu\text{A}$
Forward voltage	V_{F1}			0.24	V	$I_F=0.1\text{mA}$
	V_{F2}			0.32	V	$I_F=1\text{mA}$
	V_{F3}			0.40	V	$I_F=10\text{mA}$
	V_{F4}			0.50	V	$I_F=30\text{mA}$
	V_{F5}			1	V	$I_F=100\text{mA}$
Reverse current	I_R			2	μA	$V_R=25\text{V}$
Diode Capacitance	C_D			10	pF	$V_R=1\text{V}, f=1\text{MHz}$
Reverse Recovery Time	t_{rr}			5	nS	$I_F=I_R=10\text{mA}$ $I_{rr}=0.1I_R, R_L=100\Omega$

Typical Characteristics

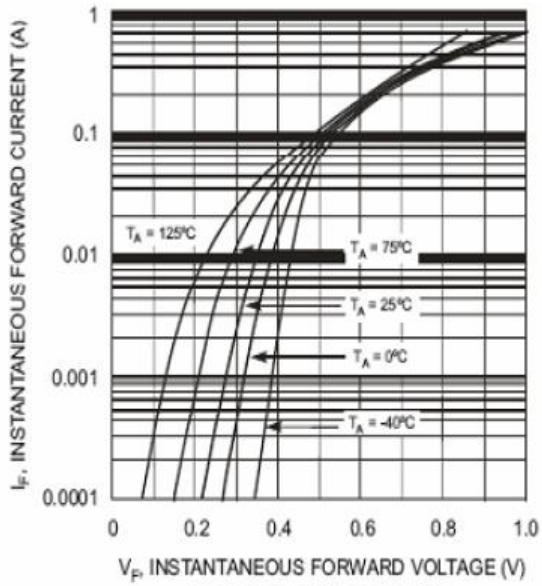

Fig. 1 Forward Characteristics

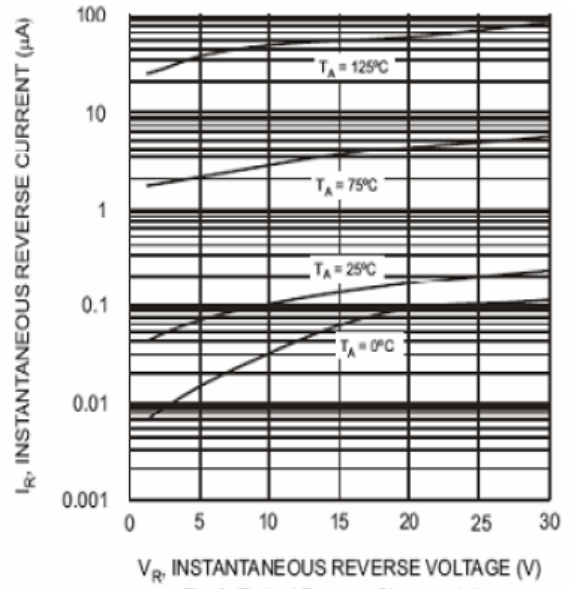

Fig. 2 Typical Reverse Characteristics

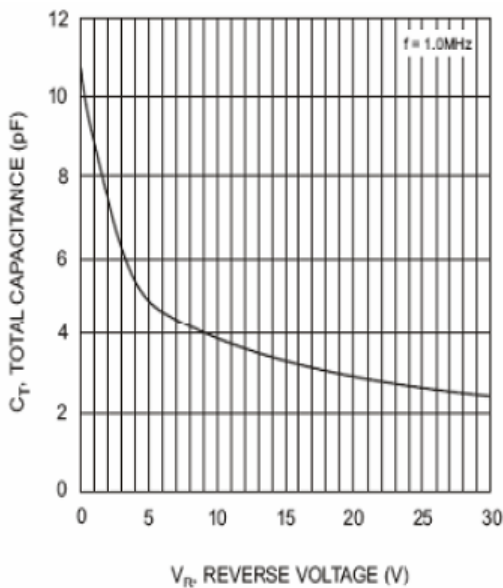

Fig. 3 Typical Capacitance vs. Reverse Voltage

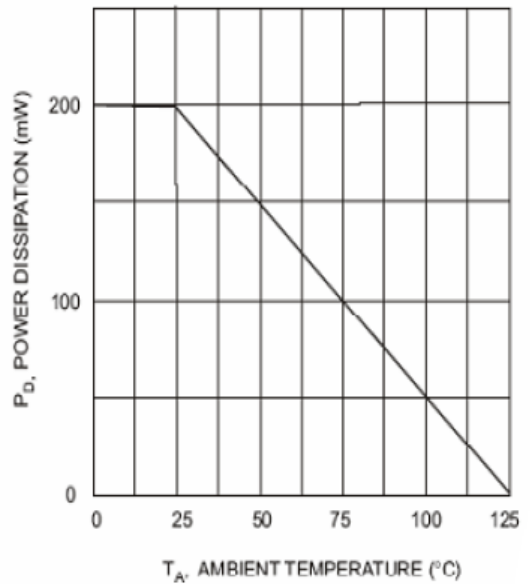

Fig. 4 Power Derating Curve